



***Mini Ozone Delivery System (ODS)***  
***Model ODS 9000 Series, V2***  
**User Manual**



© TELEDYNE API (TAPI)  
9970 CARROLL CANYON ROAD  
SAN DIEGO, CALIFORNIA 92131-1106  
USA

Toll-free Phone: 800-324-5190  
Phone: +1 858-657-9800  
Email: [api-sales@teledyne.com](mailto:api-sales@teledyne.com)  
Website: <http://www.teledyne-api.com/>



## **NOTICE OF COPYRIGHT**

© 2018 Teledyne API (TAPI). All rights reserved.

## **TRADEMARKS**

All trademarks, registered trademarks, brand names or product names appearing in this document are the property of their respective owners and are used herein for identification purposes only.

## SAFETY MESSAGES

Important safety messages are provided throughout this manual for the purpose of avoiding personal injury or instrument damage. Please read these messages carefully. Each safety message is associated with a safety alert symbol and is placed throughout this manual; the safety symbols are also located inside the instrument. It is imperative that you pay close attention to these messages, the descriptions of which are as follows:



WARNING: Electrical Shock Hazard



HAZARD: Strong oxidizer



GENERAL WARNING/CAUTION: Read the accompanying message for specific information.



CAUTION: Hot Surface Warning



Do Not Touch: Touching some parts of the instrument without protection or proper tools could result in damage to the part(s) and/or the instrument.



Technician Symbol: All operations marked with this symbol are to be performed by qualified maintenance personnel only.



Electrical Ground: This symbol inside the instrument marks the central safety grounding point for the instrument.

### CAUTION



This instrument should only be used for the purpose and in the manner described in this manual. If you use this instrument in a manner other than that for which it was intended, unpredictable behavior could ensue with possible hazardous consequences.

For Technical Assistance regarding the use and maintenance of this instrument or any other Teledyne API product, contact Teledyne API's Technical Support Department:

Telephone: 800-324-5190

Email: [sda\\_techsupport@teledyne.com](mailto:sda_techsupport@teledyne.com)

or access any of the service options on our website at <http://www.teledyne-api.com/>

## CONSIGNES DE SÉCURITÉ

Des consignes de sécurité importantes sont fournies tout au long du présent manuel dans le but d'éviter des blessures corporelles ou d'endommager les instruments. Veuillez lire attentivement ces consignes. Chaque consigne de sécurité est représentée par un pictogramme d'alerte de sécurité; ces pictogrammes se retrouvent dans ce manuel et à l'intérieur des instruments. Les symboles correspondent aux consignes suivantes :



AVERTISSEMENT : Risque de choc électrique



DANGER : Oxydant puissant



AVERTISSEMENT GÉNÉRAL / MISE EN GARDE :  
Lire la consigne complémentaire pour des renseignements spécifiques



MISE EN GARDE : Surface chaude



Ne pas toucher : Toucher à certaines parties de l'instrument sans protection ou sans les outils appropriés pourrait entraîner des dommages aux pièces ou à l'instrument.



Pictogramme « technicien » : Toutes les opérations portant ce symbole doivent être effectuées uniquement par du personnel de maintenance qualifié.



Mise à la terre : Ce symbole à l'intérieur de l'instrument détermine le point central de la mise à la terre sécuritaire de l'instrument.

### MISE EN GARDE



Cet instrument doit être utilisé aux fins décrites et de la manière décrite dans ce manuel. Si vous utilisez cet instrument d'une autre manière que celle pour laquelle il a été prévu, l'instrument pourrait se comporter de façon imprévisible et entraîner des conséquences dangereuses.

## CONTENTS

<b>NOTICE OF COPYRIGHT .....</b>	<b>1</b>
<b>TRADEMARKS .....</b>	<b>1</b>
<b>SAFETY MESSAGES .....</b>	<b>2</b>
<b>CONSIGNES DE SÉCURITÉ .....</b>	<b>3</b>
<b>CONTENTS .....</b>	<b>4</b>
<b>1. INTRODUCTION .....</b>	<b>7</b>
<b>1.1 Systems Covered by the Manual .....</b>	<b>7</b>
1.1.2 Purpose .....	7
1.1.3 Related Documents .....	7
<b>1.2 General Notes .....</b>	<b>7</b>
<b>2. SAFETY .....</b>	<b>9</b>
<b>2.1 Safety and Operation Training .....</b>	<b>9</b>
2.1.1 Operator Training .....	9
2.1.2 Maintenance Personnel Training .....	9
<b>2.2 General Safety Guidelines .....</b>	<b>10</b>
2.2.1 Unsafe Acts .....	10
2.2.2 Recommended Practices .....	11
<b>2.3 Recommended Safety Items .....</b>	<b>11</b>
2.3.1 Safety Data Sheets .....	11
2.3.2 Safety Equipment .....	11
2.3.3 Personal Protective Equipment .....	12
<b>2.4 Emergencies .....</b>	<b>12</b>
2.4.1 Disabling Power to the System .....	12
2.4.2 Standard First Aid for Toxic Exposure .....	13
2.4.3 Emergency Telephone Contacts .....	13
<b>2.5 Evacuations .....</b>	<b>14</b>
<b>2.6 System Safety Guidelines .....</b>	<b>14</b>
<b>2.7 System Safety Labels and Locations .....</b>	<b>15</b>
<b>2.8 High-voltage Hazards .....</b>	<b>15</b>
2.8.1 High-Voltage Hazard Locations .....	15
2.8.2 High-Voltage Hazards Table .....	15
2.8.3 Electrical Work Type .....	16
2.8.3 Ozone Generator Electrical Hazards .....	16
<b>2.9 Mechanical Hazards .....</b>	<b>17</b>
2.9.1 Mechanical Hazards .....	17
2.9.2 Assistance Contacts .....	17
<b>2.10 Chemical Hazards .....</b>	<b>18</b>

2.10.1	Required Process Chemicals .....	18
2.10.2	Ozone Safety.....	18
2.10.3	Oxygen Safety .....	18
2.10.4	Nitrogen Safety .....	19
2.10.5	Exhaust Safety .....	19
2.10.6	Chemical Residues .....	19
2.10.7	Safety Data Sheets (SDS) .....	19
<b>2.11</b>	<b>Other Hazards.....</b>	<b>20</b>
2.11.1	Ultraviolet (UV) Light Hazards .....	20
2.11.2	Ergonomic Height Hazards.....	20
2.11.2	Noise Hazards.....	20
<b>2.12</b>	<b>Lockout/Tagout Procedures .....</b>	<b>20</b>
<b>2.13</b>	<b>Safety Interlocks.....</b>	<b>23</b>
2.17.2	Generator Interlock Table .....	23
<b>3.</b>	<b>SYSTEM OVERVIEW .....</b>	<b>24</b>
<b>3.1</b>	<b>Generator Overview .....</b>	<b>25</b>
3.1.1	Generator Specifications .....	25
3.1.2	Generator Facility Requirements .....	25
3.1.3	Generator Front and Rear Panel Details.....	26
3.1.3.1	Rear Panel Connectors.....	26
3.1.3.2	Generator Controls and Indicators.....	27
<b>4.</b>	<b>INSTALLING THE SYSTEM .....</b>	<b>28</b>
<b>4.1</b>	<b>Site Preparation.....</b>	<b>28</b>
<b>4.2</b>	<b>System Dimensions .....</b>	<b>29</b>
4.2.1	Mounting .....	31
4.2.2	Service Space Requirements .....	31
4.2.3	Environmental Considerations .....	31
<b>4.3</b>	<b>Receiving the System .....</b>	<b>31</b>
4.3.1	Report any Shipment Damage .....	31
4.3.2	Storing the System .....	31
<b>4.7</b>	<b>Installing the System.....</b>	<b>32</b>
4.7.1	Making Water and Gas Connections.....	32
4.7.2	Making Electrical Connections.....	33
4.7.3	Install/Verify Operation of Leak Detection Equipment .....	34
<b>4.8</b>	<b>System Interlock Testing.....</b>	<b>34</b>
<b>5.</b>	<b>SYSTEM OPERATION .....</b>	<b>35</b>
<b>5.1</b>	<b>Initial System Startup.....</b>	<b>35</b>
5.1.1	Leak Test the System .....	36
5.1.2	Normal Operation (Local Mode).....	37
5.1.3	Normal Operation (Remote Mode Constant).....	37
5.1.4	Normal Operation (Remote Mode Servo).....	37
<b>5.2</b>	<b>Emergency System Shutdown .....</b>	<b>37</b>
<b>5.3</b>	<b>Normal System Shutdown and Purge .....</b>	<b>38</b>

<b>6. PREVENTATIVE MAINTENANCE SCHEDULES .....</b>	<b>39</b>
<b>6.1 Solid Waste Disposal .....</b>	<b>39</b>
<b>6.2 Monthly Preventative Maintenance .....</b>	<b>39</b>
<b>6.3 Yearly Preventative Maintenance .....</b>	<b>39</b>
6.3.1 MFCs .....	39
6.3.2 Ozone Sensor Maintenance .....	39
<b>7. TROUBLESHOOTING .....</b>	<b>41</b>
<b>7.1 Ozone Generator .....</b>	<b>41</b>
7.1.1 Status Fault Troubleshooting .....	41
7.1.2 Performance Fault Troubleshooting .....	42
<b>7.2 SCI-552 Controller .....</b>	<b>43</b>
<b>7.3 Technical Assistance .....</b>	<b>43</b>



## 1. INTRODUCTION

The Mini Ozone Delivery System (ODS) is a compact system designed to produce high concentrations of ozone for a wide range of wafer applications. This manual provides information and operation instructions for the Mini ODS 9000, V2 series.

### 1.1 SYSTEMS COVERED BY THE MANUAL

This manual covers the following Mini Ozone Delivery System (ODS), ODS-9000, V2 series models only:

- ODS-9005
- ODS-9010
- ODS-9025

#### 1.1.2 PURPOSE

This manual provides the following information for the Mini ODS Model ODS-9000, V2 series:

- system safety
- system description
- site preparation/installation
- operation
- maintenance

#### 1.1.3 RELATED DOCUMENTS

The support documents that accompany this manual in its binder include supplemental manuals, diagrams, schematics, and Safety Data Sheets (SDS) for ozone and for the mercury arc lamp.

## 1.2 GENERAL NOTES

This document is Copyright Protected.

Teledyne API (TAPI) reserves the right to make changes to the product covered in this manual to improve performance, reliability or manufacturability. Make sure that this manual is used with the original product it was shipped with. Although every effort has been made to ensure accuracy of the information contained in this manual, TAPI assumes no responsibility for inadvertent errors. Contents of the manual are subject to change without notice.

This product is not intended or recommended by TAPI for use in (a) medical therapy or physical therapy of any kind whether as a direct or adjunct part of such therapy, including, without limitation, life support (i.e., critical medical) applications or (b) any nuclear facility applications. Use of this product in connection with medical or like treatment cannot be reasonably expected to produce accurate monitoring of therapy or



## Mini ODS 9000, V2

treatment and may cause failure of the life support device or significantly affect its safety or effectiveness. Use by any direct purchaser or after-market purchaser in such applications whether or not known to TAPI shall absolve TAPI of any responsibility or liability to such purchaser (s) or to any person (s) subjected to or affected by such use knowingly or unknowingly.

## 2. SAFETY

As with all equipment, basic operation procedures and all associated safety precautions should be reviewed and thoroughly understood before operating the equipment.

### 2.1 SAFETY AND OPERATION TRAINING

While formal training is not required for operators, each operator should read this manual and review the safety items and system shutdown procedures.

#### 2.1.1 OPERATOR TRAINING

It is strongly advised that before working with the system, the user be trained in:

- identification of the recognized hazards associated with each task
- identification of, and appropriate responses to, usual operating conditions, and any emergency situations, including the use of all system controls, and any EMO buttons
- an explanation of the functions and limitations of all safeguards and their design characteristics
- an explanation for function testing or otherwise assuring the proper functioning of safeguarding devices.
- General Safety
- System Safety
- System/Subsystem Descriptions
- System Shutdown

#### 2.1.2 MAINTENANCE PERSONNEL TRAINING

Maintenance personnel should review system documentation and know safety and system startup/shutdown procedures. Topics of focus would include:

- General Safety
- System Safety
- System/Subsystem Review
- System Startup
- System Interlock Testing
- System Shutdown
- Lockout/Tagout Procedures
- Lamp Replacement Procedure

Such items are addressed in this manual and its related documents to support experienced maintenance personnel in safely and efficiently performing each task.

## 2.2 GENERAL SAFETY GUIDELINES



### CAUTION

- Always follow established industrial safety practices when operating any production equipment.
- Safety is designed into every TAPI system. When followed, these minimum guidelines provide an acceptable level of safety for operating and maintaining your system. They are not, however, a substitute for determining your own internal safety procedures.
- Use of controls, adjustments, or procedures other than those specified in this manual without consulting a competent safety professional may result in exposure to potential hazards. Always follow established industrial safety practices when operating production equipment.
- Failure to comply with the safety precautions or warnings indicated in this manual violates the safety standards that form a part of the intended use of the ozone generating equipment. TAPI assumes no liability for the user's failure to comply with these requirements.

### 2.2.1 UNSAFE ACTS

- NEVER let elastomer seals such as Viton<sup>®</sup> or Buna<sup>®</sup> N come into contact with ozone.
- NEVER begin operation of the system until the proper process equipment has been linked to the system, and has been signed-off and is ready for processing and receiving inputs from this system.
- NEVER defeat a safety interlock unless you are certified to perform the procedure and have been specifically directed to defeat the interlock.
- NEVER open a system panel when water, or electrical power is turned on to the system.
- NEVER operate or service this system without a thorough knowledge of the dangers involved and the precautions to be followed for safe and efficient operation.
- NEVER disregard instructions to lockout/tagout the system.
- NEVER permit unauthorized or untrained personnel to access, use, or perform maintenance on the system.
- NEVER STAND IN WATER OR ON A WET SURFACE WHILE OPERATING ANY ELECTRICALLY POWERED EQUIPMENT.
- NEVER remove a warning label from the equipment.
- NEVER operate damaged or leaking equipment.
- NEVER allow any foreign material to enter the ozone generator.
- NEVER substitute any feedstock gases not specified in this manual without explicit permission from TAPI.

## 2.2.2 RECOMMENDED PRACTICES

- **USE THE BUDDY SYSTEM:** ALWAYS perform maintenance procedures in teams of two or more people; one to monitor the surrounding systems, the maintenance environment, your actions and to ensure that all documentation and safety steps are followed. Always seek additional help when:
  - You are instructed by any procedure.
  - You see an emergency or dangerous situation.
  - You are not trained or qualified/certified to perform a task.
  - You feel uncomfortable performing a task.
  - You need assistance lifting heavy or awkward panels or equipment. ALWAYS seek help when lifting any item that weighs more than 40 lbs.
- ALWAYS observe all warning labels.
- ALWAYS follow safety guidelines and avoid all unsafe acts (review Section 2.2).
- Connect all input gas and electrical lines according to the manufacturer specifications or best commercial practice.
- Always check the fittings of all ozone, oxygen, and water lines before operating.
- Whenever possible, make sure that both gases and power are turned OFF at the source prior to beginning any maintenance task.

## 2.3 RECOMMENDED SAFETY ITEMS

### 2.3.1 SAFETY DATA SHEETS

You must make sure that Safety Data Sheets (SDS) covering all hazardous material used in or for the system are easily available in the immediate vicinity of the equipment. TAPI provides SDSs covering those chemical substances which are inherent in, or shipped with, the equipment. These include:

- Ozone
- Mercury Arc Lamp

For those gas or chemical substances that are used with the system or for processing, maintenance, or service of equipment, but are not provided in or with the equipment, you must obtain the SDSs from their suppliers. These can include but are not limited to:

- Oxygen
- Nitrogen

### 2.3.2 SAFETY EQUIPMENT

All safety equipment should be clearly marked, easily accessible, and located in the immediate vicinity of the equipment. We recommend that you have the following additional safety equipment readily available to you:

- First aid kit
- Fire protection equipment (proper fire extinguisher, etc.)
- Protective clothing including glasses rated for UV protection as noted in the system maintenance procedures.

Also make sure that all personnel are both familiar with and trained in the use and handling of the safety equipment in your area.

*NOTE:* Approval of these items for use at the customer facility is not the responsibility of TAPI. The procurement, installation, operation, and maintenance of all safety equipment is the sole responsibility of the customer.

The safety equipment described in this guide is not intended to provide protection for all hazards. Protection of the customer's property, employees, and guests is the sole responsibility of the customer.

### 2.3.3 PERSONAL PROTECTIVE EQUIPMENT

The following personal protective equipment is required for the safe maintenance of this equipment:

- Safety goggles with permanent side shields meeting ANSI Z87.1 requirements.
- Safety goggles with UV protection rated for up to 40  $\mu\text{W}/\text{cm}^2$

## 2.4 EMERGENCIES

This section presents some guidelines for emergency situations and first aid for toxic exposure.

### 2.4.1 DISABLING POWER TO THE SYSTEM

An EMERGENCY OFF (EMO) button is recommended for installation by the end-user to remove power from the system in an emergency situation. If an EMO is not installed on your equipment, turn OFF the power switch on the ozone generator to stop ozone generation.

#### **WARNING**



**If the TAPI components are installed in a system where an EMO is activated, power may remain on the input side of a main contactor, and within any surge protectors and any power distribution boxes. Consult the on-site installation/equipment engineer for custom installation and requirements.**

## 2.4.2 STANDARD FIRST AID FOR TOXIC EXPOSURE

If exposure to a toxic substance occurs:

1. Protect yourself from the hazard by wearing appropriate protection equipment before assisting others.
2. Contact an emergency assistance partner, group or agency to assist you.
3. Remove the victim from the immediate area and place him/her in an uncontaminated area.
4. If the victim has stopped breathing, administer artificial respiration.
5. Administer oxygen if required.
6. Contact the local poison control center or other emergency medical assistance (identify, if possible, the chemical that the person was exposed to).
7. Keep the victim calm and warm until medical assistance arrives.
8. Describe the chemical or gas that the person was exposed to, to the attending physician or medical personnel.

## 2.4.3 EMERGENCY TELEPHONE CONTACTS

Make sure that you have a list of emergency telephone numbers for your locality displayed outside of the immediate area of the equipment. The list should contain emergency numbers for the following:

Contact	Telephone Number(s)
Poison Control Center	
Ambulance	
Hospital	
Fire Department	
Internal Safety Personnel Contact	

*NOTE:* Since your local poison control center is more familiar with the toxic substances used in the semiconductor industry, this should be your primary contact for these types of situations prior to a local physician or hospital.

## 2.5 EVACUATIONS

In case of an emergency evacuation:

- EXIT the building through the nearest exit and report to your assigned evacuation area.
- DO NOT stop to turn off any machines.
- DO NOT move any carts or equipment during evacuation.
- Obey all commands from the emergency response team.
- Return to the building ONLY AFTER being instructed to do so by the emergency response team.

## 2.6 SYSTEM SAFETY GUIDELINES

The following important messages are provided for personal safety and for protection of equipment:



### WARNING – Electrical Shock Hazard

When performing any maintenance to the unit, make sure all AC power is disconnected from the unit.



### HAZARD – Strong Oxidizer

- Ozone (O<sub>3</sub>) is a toxic gas. High concentrations of ozone are dangerous and harmful to humans. Take reasonable steps to avoid exposure. The current maximum 8-hour exposure limit for ozone is 0.1 PPM (according to U.S. OSHA).
- Install appropriate safety monitoring equipment wherever high concentrations of ozone are used. (TAPI manufactures several ozone monitors for workplace safety applications).
- Never attempt to open ozone catalyst canisters (if supplied). The contents of the canisters can be hazardous if not handled properly.



### CAUTION – UV EXPOSURE

The ozone monitor contains an ultraviolet (UV) lamp. Never remove the lamp from its housing while the unit is powered on. Eye exposure to UV light is extremely dangerous.



### CAUTION – Hot Surface Warning

Certain components may be hot to the touch. Please allow proper cooling time before working with these components.



**CAUTION**



- **Materials in contact with high concentrations of ozone should be suitable for such use. Stainless Steel (316L), Teflon<sup>®</sup>, Chemraz<sup>®</sup> and Kynar<sup>®</sup> are recommended.**
- **Use only TAPI recommended spare parts. Substitution parts could result in damage to the equipment, may create hazardous conditions and will void the warranty.**
- **Use this equipment as recommended in this manual. Use of the equipment in ways other than specified by TAPI may create hazardous conditions.**
- **Do not subject the unit to extreme physical or thermal shock. Use care in handling the unit and any of its components.**

## 2.7 SYSTEM SAFETY LABELS AND LOCATIONS

Safety-warning labels are intended to warn the users about the toxicity and danger of ozone gas and electrical dangers. They are applied where appropriate on the outside covers of components and panels.

## 2.8 HIGH-VOLTAGE HAZARDS

**WARNING**



**The Mini ODS uses high voltages that can cause injury or death by electrical shock. Personnel working with or near high voltage equipment should be thoroughly familiar with emergency equipment, procedures, and resuscitation methods as well as electrical safety work practices and procedures for the control of hazardous energies.**

### 2.8.1 HIGH-VOLTAGE HAZARD LOCATIONS

High voltages are used in the process of generating ozone; however, all circuits of the generator are either covered or isolated. The generator cannot be opened without tools. The ozone generator power connection is also covered. The ozone generator does not need to be opened for any routine maintenance. In the event that the unit needs to be serviced, all work should be completed by trained/certified and authorized personnel only. Prior to working on the ozone generator, remove electrical power by switching off the Circuit Breaker located on the generator's front panel and unplugging the power cord.

### 2.8.2 HIGH-VOLTAGE HAZARDS TABLE

High-voltage Hazard	Location	Voltage	Description/Safety Interlocks
SCI-552 Controller	Cabinet or Rack-Mount Components	90 to 240VAC	Power-cord plug-in component.
Ozone Generator		200-240 VAC	

### 2.8.3 ELECTRICAL WORK TYPE

All maintenance procedures should be performed with the system fully de-energized. In accordance with the *Environmental, Health, and Safety Guideline for Semiconductor Manufacturing Equipment* (SEMI S2-0703aE), section 13, each maintenance procedure has been assigned an electrical work type code. The codes are from 1 to 4 with 4 being the most hazardous task. See *Environmental, Health, and Safety Guideline for Semiconductor Manufacturing Equipment* (SEMI S2-0703aE) for additional information.

Electrical Work Type	Energy Magnitude	Condition	Safety Buddy Required
1	0 volt amps	Fully de-energized and locked and tagged out.	No
2	Energized with covers in place	Energized, but live circuits are covered or insulated to prevent accidental shock. Type 2 work includes tasks where the energized circuits are or can be measured by placing probes through suitable openings in the covers or insulators.	No
3	<240 Volt amps and <60 Volts	Equipment is energized. Energized circuits are exposed and inadvertent contact with uninsulated energized parts is possible. Potential exposures are no greater than 30 Vrms, 42.4V peak, 60 VDC or 240 VA in dry locations.*	No
4	>240 Volt amps and >60 Volts	Energized and live circuits are exposed and accidental contact is possible at greater than 30 Vrms, 42.4V peak, 60 VDC or 240 VA in dry locations.* Potential exposure to radio-frequency currents.	Qualified Energized Electrical Work Buddy

\* A dry location can be considered to be one that is not normally subject to dampness or wetness.

### 2.8.3 OZONE GENERATOR ELECTRICAL HAZARDS

The ozone generator produces high voltages inside its housing. An ozone generator cannot be opened without tools. Its electrical connections are also covered. The ozone generator should never be opened except by service technicians who are specifically trained/certified and authorized to serve the generators.



#### WARNING – ELECTRICAL HAZARD

The Mini ODS uses high voltages that can cause injury or death by electrical shock. Wait at least 10 minutes before you touch any part inside the generator after de-energizing! Electrical charge may be stored in capacitors.

## 2.9 MECHANICAL HAZARDS

This section addresses electrical, chemical (gas), mechanical, and other hazards

### 2.9.1 MECHANICAL HAZARDS

Mechanical hazards can include pinch or drop hazards with the removal of any system component, such as with rack mounted system components if the end-user chooses to mount the system in a rack.

<b>QUALIFIED TECHNICIAN</b>	
	<p><b>You MUST be trained on the use the system to prior to attempting to install, operate or perform maintenance on the system. Your training must include:</b></p> <ul style="list-style-type: none"><li>• a review of all applicable industry safety procedures and standards</li><li>• a review of all system safety recommendations</li><li>• a thorough understanding each subsystem and its operation</li><li>• a detailed explanation of the specific tasks and responsibilities of each person involved in the use of the ozone generator system</li><li>• the person or persons (by name, location and phone number) to contact when the actions required are beyond the training and responsibility of the person being trained</li></ul>

### 2.9.2 ASSISTANCE CONTACTS

Names/Locations/Phone Numbers:

---

---

---

---

---

---

## 2.10 CHEMICAL HAZARDS



### CAUTION

Safety Data Sheets are required for immediate availability near the equipment. See Section 2.3.1

### 2.10.1 REQUIRED PROCESS CHEMICALS

Chemical	Location
Nitrogen (N <sub>2</sub> )	Facility supplied, rear of system
Oxygen (O <sub>2</sub> )	Facility supplied, rear of system
Ozone (O <sub>3</sub> )	Created by the system.
Mercury	Trace amounts in the system UV lamps.

### 2.10.2 OZONE SAFETY

Ozone has the potential to injure humans and damage the equipment and facilities by corrosion or explosion. One should also be aware of chemical and physical risks.

#### HAZARD: STRONG OXIDIZER



- Understand and implement the OSHA and locally required safety laws involving the generation of ozone gas using high-voltages. Failure to do so may lead to personnel injury. Do not use this system without an ozone leak monitor. TAPI assumes no liability for the user's failure to comply with these requirements.
- Observe the necessary safety measure when working with high ozone concentrations. (Refer to the website for your governing agency for specifics).
- Ozone has a readily identifiable odor recognizable in extremely minute quantities. Observe the safety thresholds for ozone concentration. Concentrations above 0.1 ppm can cause headaches, eye irritation, respiratory problems, dizziness, and nausea. At much higher concentrations it can cause death.
- An alternative method to locate small leaks on tubing and fittings that contain ozone is the use of commercially available potassium iodide starch paper. When moistened with distilled water, it indicates the presence of gaseous oxidizers.
- Never use materials which catalyze the decay of ozone within the gas lines. DO NOT use silver plated gaskets for VCR fittings since they catalyze the decay of ozone severely. Use non-plated stainless steel gaskets only.

### 2.10.3 OXYGEN SAFETY



**CAUTION - FIRE/EXPLOSION HAZARD**

**Non-flammable materials may become flammable in the presence of high oxygen and/or ozone concentrations.**

The feed gas for the ozone generator is oxygen gas spiked with traces of nitrogen. If the exhausting of the cabinet fails, an accumulation of oxygen may occur if there is a leak in the oxygen tubing. It is recommended to install a flow-limiting device in your facility oxygen tubing; however, a small leak may not trigger the flow-limiting device and oxygen can still accumulate.

### 2.10.4 NITROGEN SAFETY



**CAUTION - INHALATION HAZARD**

**Inhalation of nitrogen in high concentrations causes suffocation.**

If there is a leak in Nitrogen tubing, an accumulation of Nitrogen may occur near or adjacent to the leak location or at a remote area where the gas is allowed to flow.

### 2.10.5 EXHAUST SAFETY



**CAUTION – INHALATION HAZARD**

**Inhalation of exhaust gases can cause serious injury or suffocation.**

All ozone generating equipment should be housed in an area with proper exhaust and with proper sweep of the installation location/cabinet and an ozone leak detector should be installed to detect any leaks. A flow sensor with interlock on an exhaust port should be installed to ensure that insufficient exhaust will trip the exhaust interlock and turn off the ozone generators.

### 2.10.6 CHEMICAL RESIDUES



**CAUTION - CHEMICAL EXPOSURE**

**Ensure that the system is properly purged and shutdown prior to performing maintenance. Avoid direct contact with any residues.**

Trace amounts of mercury are contained in the UV bulbs. Protective glasses and gloves, at a minimum, should be worn when replacing UV bulbs.

### 2.10.7 SAFETY DATA SHEETS (SDS)

Safety Data Sheets (SDS) for each hazardous chemical should be consulted in case of exposure. The SDS covering all hazardous materials used in the process must be easily available for review in the immediate vicinity of the equipment. TAPI provides SDSs covering those chemical substances which are inherent in, or shipped with this equipment, and can be found within the system documentation provided; these include:

- Ozone

- Mercury Arc Lamp

For those gas or chemical substances that are used with the system or for processing, maintenance, or service of equipment, but are not provided in or with the equipment, you must obtain the SDSs from their suppliers. These can include but are not limited to: Oxygen and Nitrogen.

## 2.11 OTHER HAZARDS

### 2.11.1 ULTRAVIOLET (UV) LIGHT HAZARDS



#### CAUTION - UV HAZARD

**DO NOT** look directly at a UV light as permanent eye damage may result. Use appropriate protection for eyes and for skin.

A UV lamp is located inside the ozone sensor detectors. Lamp life is typically 12-24 months.

The lamps are shielded by multiple cabinet and component covers and present no exposure hazards to the operator during system operation. Follow lamp replacement instructions to avoid exposure to any UV light during system maintenance.

### 2.11.2 ERGONOMIC HEIGHT HAZARDS



#### CAUTION –TRIP or FALL HAZARD

**Never** install the system components in a location where it is difficult or dangerous to reach.

### 2.11.2 NOISE HAZARDS

The system emits less than 50db and presents no noise hazard.

## 2.12 LOCKOUT/TAGOUT PROCEDURES



#### WARNING - RISK OF SERIOUS INJURY or DEATH

If you do not lockout and tagout the system, you risk serious injury or death from contact with or exposure to hazardous energies such as electricity, hazardous materials, and moving mechanisms.



#### QUALIFIED TECHNICIAN REQUIRED

Perform work on the equipment in a safe manner. Only complete work on the system if you are authorized and if you have applied your own lockout/tagout device.

A lockout/tagout program helps to prevent injury from unexpected energization,

start-up, or release of stored energy from the equipment during maintenance or service. A lockout/tagout program controls hazardous energies (electrical, mechanical, chemical, physical, etc.). The lockout/tagout procedure isolates the energies from the service area and locks the isolation device to ensure that the energy is not reapplied to the equipment during maintenance and service.

You must use lockout/tagout procedures (or an alternative which provides effective protection) when:

- a safety device is bypassed
- any part of your body is close to any point of operation or associated danger zone of the equipment.

You are responsible for your own safety. If you are authorized to perform maintenance, you must apply your own personal locks and tags at required energy isolation points prior to working on the equipment. You must not share locks and tags. If more than one person is performing maintenance on the equipment, each person's lock and tag must be placed at each energy isolation device. If necessary, use a lock-extender clamp which can typically support up to six individual locks.

You are not required to lockout/tagout cord-and-plug connected equipment provided that the plug remains under your control at all times.

**Table 1. Electrical Lockout/Tagout Sites for Power Distribution Panel**

Circuit Breaker	Location
Main	Facilities

**Table 2. Gas Lockout/Tagout Sites**

Gas	Location
Nitrogen	Facilities
Oxygen	Facilities

1. Notify Affected Personnel  
Before starting the maintenance procedures, notify anyone who may be affected.
2. Prepare for Shutdown  
Before shutting down the equipment, determine the energies present, their hazards, and the means for controlling them. Also, collect the following:
  - Any written maintenance procedures
  - Proper maintenance tools
  - Appropriate locks, tags, and other energy isolating devices
3. Apply the Lockout/Tagout  
If you are working on the equipment, apply your own lock and tag to each energy isolating device. Always make sure lockout devices are tagged with the name of the individual who is applying the lock as well as the reason for the maintenance procedure. Apply the lockout so that the energy isolating devices are held securely in the "SAFE" or "OFF" position.
4. Release Stored Energy

Dissipate any hazardous energy which remains in the equipment after you have applied the isolating device and the locks and/or tags. Make sure you are authorized to release the energy and you release it in a safe manner. Gas hazardous energies can include pressure, suffocation potential, poison potential, etc. Ensure that hazardous energies do not re-accumulate.

5. Verify the Isolation

Before beginning work on a locked-out equipment, verify that the equipment is in a zero energy state by attempting to turn ON the controls designed for that purpose. You may also wish to verify the isolation with an appropriate meter. After verifying that the lockout/tagout is working, return the system to the "OFF" or "NEUTRAL" position.

6. Perform the Task

7. Inspect the Equipment

Following completion of the work, inspect the equipment to ensure that it has been properly reassembled and is fit for operation. All guards, interlocks, and other safety devices must be in place. Verify that all tools, used parts, cleaners, and wipes have been removed from the equipment.

8. Notify Affected Personnel

Clear the area of all personnel before re-starting the equipment.

Inform anyone affected that the locks and/or tags are about to be removed from the equipment.

9. Remove your lock(s) and tag(s) Remove the locks and/or tags only if:

- You are authorized to remove them
- You applied the locks and tags
- Energy isolating devices are ready to be restarted

10. Re-start the Equipment

Monitor the start-up of the equipment for malfunctions from an appropriate, safe position. If the system malfunctions, you must shut down the equipment and repeat the lockout/tagout process.



## 2.13 SAFETY INTERLOCKS

The system should be installed with appropriate safety interlocks and ozone monitoring equipment.

At a minimum, interlocks should include:

- EMO button interlocks for operator protection
- ozone leak detection
- cooling water flow
- panel/covers/equipment access

TAPI highly recommends using one of our ozone monitors to detect leaks, as well as our Model CAT-O3 Ozone Destruct Unit.

### 2.17.2 GENERATOR INTERLOCK TABLE

NOTE: All interlocks latch when they are triggered; to clear, address the issue and toggle the RESET switch on the front panel

Interlock	Location	Requirement	Interlock Method	Consequence if tripped	Operator Notification
Host tool connection	Cable connection at rear of system.	24 VDC interface connection	hardware trip switch	Shutdown of ozone production	<ul style="list-style-type: none"> <li>• External Interlock on Control Panel</li> </ul>
Cooling water flow	internal to the ozone generator	minimum of 1.5 gpm per generator	hardware trip switch	Shutdown of ozone production	<ul style="list-style-type: none"> <li>• visual indicator on control panel</li> </ul>

### 3. SYSTEM OVERVIEW

#### CAUTION - FIRE/EXPLOSION HAZARD



The Ozone Delivery System is shipped with the ozone, gas and water ports capped-off. Remove these caps and connect the system to appropriate plumbing before running the system.

Read this manual carefully before applying power, oxygen, nitrogen or water to the Ozone Delivery System. Verify that gas can flow freely out of the DIVERT port and into a suitable destruct unit before applying oxygen or nitrogen to the system.

Non-flammable materials may become flammable in the presence of high oxygen and/or ozone concentrations.

The Mini ODS consists of two main components:

- ODS-9000, V2 series, high-purity ozone generator
- SCI-552 controller

The ozone generator contains ozone generating equipment and controls including oxygen and nitrogen Mass Flow Controllers (MFCs), an in-line ozone concentration sensor (Model 452), and a remote pneumatically-controlled diverter switch to direct ozone to the PROCESS tool or to DIVERT (ozone destructor).

The SCI-552 Controller connects to the ozone generator and controls the flow rate of each process gas, ensures safety interlocks are met, and displays ozone concentrations.



### 3.1 GENERATOR OVERVIEW

Information and instructions for the SCI-552 Controller are available in its manual, included with system binder.

#### 3.1.1 GENERATOR SPECIFICATIONS

Dimensions (W x H x D)	19" x 10.5" x 18" (48 cm x 27 cm x 46 cm)	
Oxygen Flow	<b>Model</b>	<b>Range (sccm O<sub>2</sub>)</b>
	ODS-9005	100 - 1000
	ODS-9010	200 - 2000
	ODS-9025	300 - 5000
Ozone Outlet Pressure	Internally set to 30 PSIG	
Proof Pressure	80 PSIG	
Ambient Temperature	5 – 35 °C	
AC Power	200-240VAC 1 $\phi$ , 50/60 Hz, 10 AMPS	
Cooling Water Temperature	18 °C $\pm$ 3 °C (do not cool below local dew point)	
Cooling Water Flow	2.0 GPM at 60 PSIG	
Weight	70 Lbs. (37 kg)	

#### 3.1.2 GENERATOR FACILITY REQUIREMENTS

Gas Service	Oxygen	Grade 6 or better. Less than 1 PPM water, hydrocarbon and halocarbons. 50 PSIG delivery pressure
	N <sub>2</sub> (Spiking Gas)	Grade 5 or better 0.5% of total feed gas volume N <sub>2</sub> 55 PSIG delivery pressure
	Feed-gas Inlet Ports	¼ " VCR male
	Ozone Outlet Ports	¼ " VCR male
	CDA	¼ " Compression, 60 PSI Typ (80 PSI Max)
Cooling Water	Temperature	18 °C $\pm$ 3 °C (keep water temperature above local dew point)
	Recommended Flow	2.0 GPM
	Minimum Flow	1.5 GPM
	Max Inlet Pressure	80 PSIA
	Filtration	20 Microns or better (Customer Supplied)
	Quality	Demineralized
	Thermal Load	2.0 KW
Water Supply/Return Port	1/2" Compression (female)	
Electrical Service	AC Power	200-240VAC, 50/60 Hz 1 $\phi$
	Current	10 AMP

### 3.1.3 GENERATOR FRONT AND REAR PANEL DETAILS

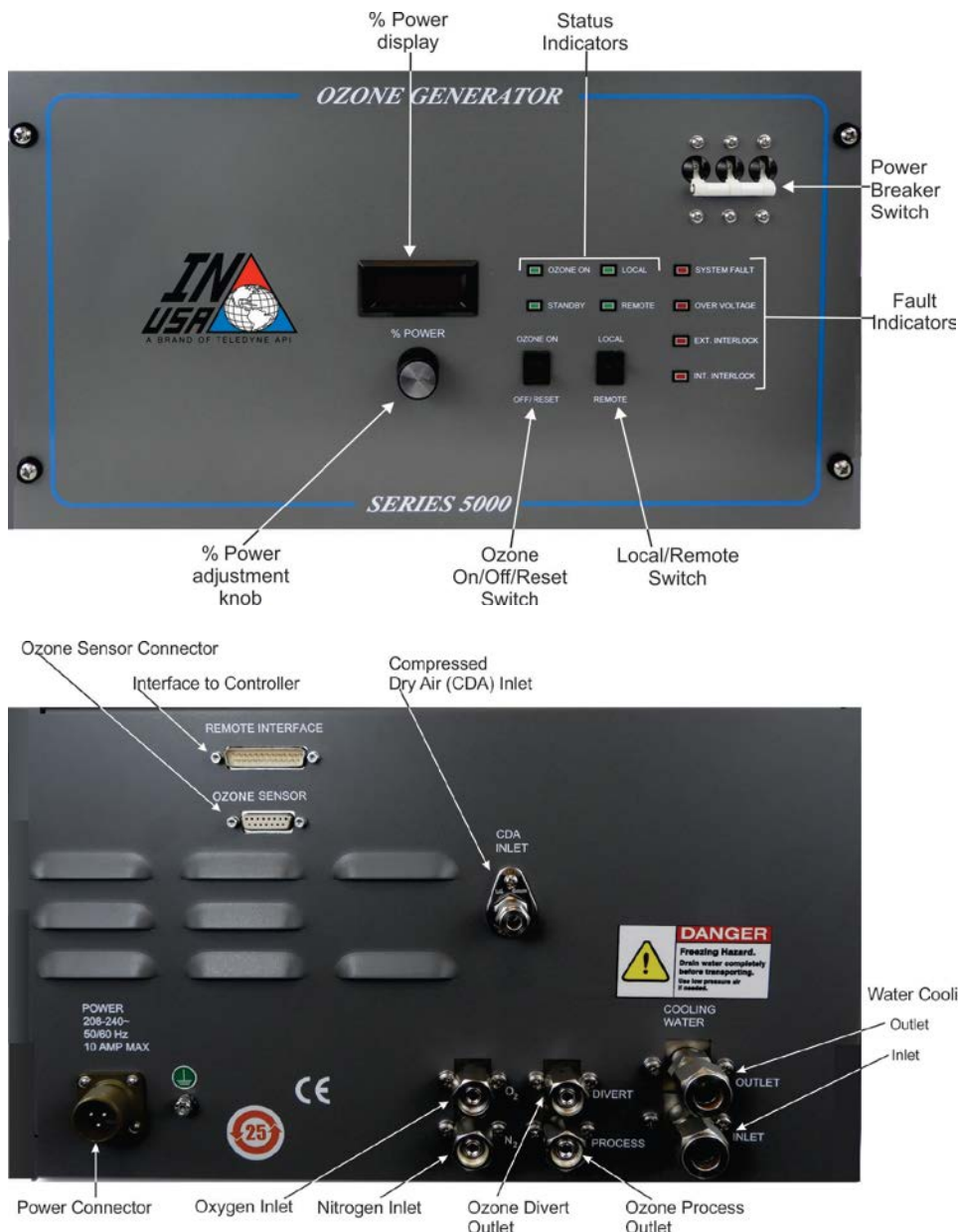

#### 3.1.3.1 REAR PANEL CONNECTORS

Electrical Connectors	Main power input DB-25 electrical connector for remote interface with the SCI-552 Controller DB-15 electrical connector, "Ozone Sensor", associated to the internally mounted ozone sensor, for connection to the SCI-552 Controller
Cooling water Connectors	Cooling Water Inlet Port Cooling Water Outlet Port
Inlet Gas Connectors	Feed Gas Inlet Port, Oxygen Feed Gas Inlet Port, Nitrogen Compressed Dry Air (CDA)
Outlet Gas Connectors	Divert Outlet Port, Ozone Process Outlet Port, Ozone

### 3.1.3.2 GENERATOR CONTROLS AND INDICATORS

POWER BREAKER SWITCH	This breaker is used to switch the AC power to the unit. When the switch is in the ON position (breaker UP) the main AC power is applied to the unit's control circuitry. When the switch is in the OFF position (breaker down) no AC power is present on the control circuitry.
OZONE ON – OFF/RESET SWITCH	When the switch is set to the OZONE ON position the control electronics will attempt to deliver the set-point power to the generating cells. When the switch is set to the OFF/RESET position, the control electronics will remove power from the generating cells.
LOCAL – REMOTE SWITCH	In the LOCAL position it selects Local operation from the Front Panel Controls, in the REMOTE position it selects remote-controlled operation via the connector located in the Rear Panel.
% POWER Adjustment knob	This potentiometer controls the amount of power delivered to the generating cells (and ultimately the amount of ozone being generated).
Status LEDs	
OZONE ON	This indicator is ON when power is applied to the generating cells, and no alarm conditions are present.
STANDBY	This indicator is ON when the generator is ready to make ozone and there is no alarm condition detected.
LOCAL	This indicator is ON when the Local Mode of Operation has been selected.
REMOTE	This indicator is ON when the Remote Mode of Operation has been selected.
Fault LEDs	
SYSTEM FAULT	This indicator is ON when the control electronics detects an over-temperature condition in either the High Voltage Power Supply's switching transistors; the power magnetic components; or the generating cells. The control electronics shuts off the HVPS and the unit remains in this state until a reset signal is detected.
OVER VOLTAGE	This indicator is ON when an over-voltage condition is detected at the high voltage power supply (HVPS). The control electronics shuts off the HVPS and the unit remains in this state until a reset signal is detected.
EXT. INTERLOCK	This indicator is ON when the EXT. INTERLOCK signal (Pin #12 in the REMOTE- INTERFACE CONNECTOR) is HIGH.
INT. INTERLOCK	This indicator is ON when the control electronics detects that the internal interlock conditions are not met. This indicator is ON if there is not enough chilled water flow.

Refer to controller manual for connection instructions and pin assignments

## 4. INSTALLING THE SYSTEM

This section presents system dimensions and other installation information.

### 4.1 SITE PREPARATION

Before the system arrives:

1. Use the component drawing as a reference for your space requirements.
2. Verify that all system gas hookups:
  - Nitrogen feeds and shutoff valves
  - Oxygen feeds and shutoff valves
3. Verify all cooling water hookups:
  - cooling water inlet/return connections
  - water flow meter needs to be installed on the cooling water lines
  - sensor and means of stopping water flow
4. Verify all power hookups:
  - Power outlets (2, one for each component)
5. Verify EMO protection hookup:
  - Install an EMO switch in the facility since the ozone generator system does not contain an EMO shutdown
6. Verify ozone leak and exhaust protection hookups:
  - Ozone leak detectors in system exhaust and in desired protection areas
  - Ozone destructor installed for divert/exhaust flow

## 4.2 SYSTEM DIMENSIONS

The following illustrations provide dimensions (in inches) for installation planning purposes:

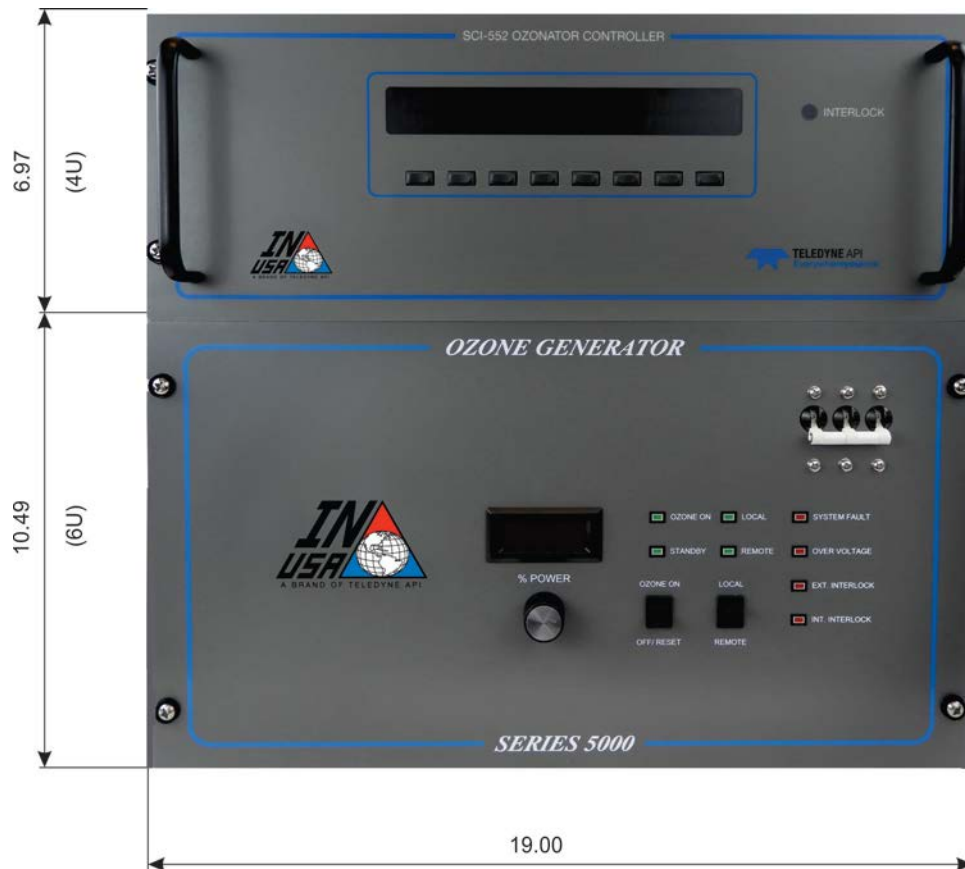

### Rear

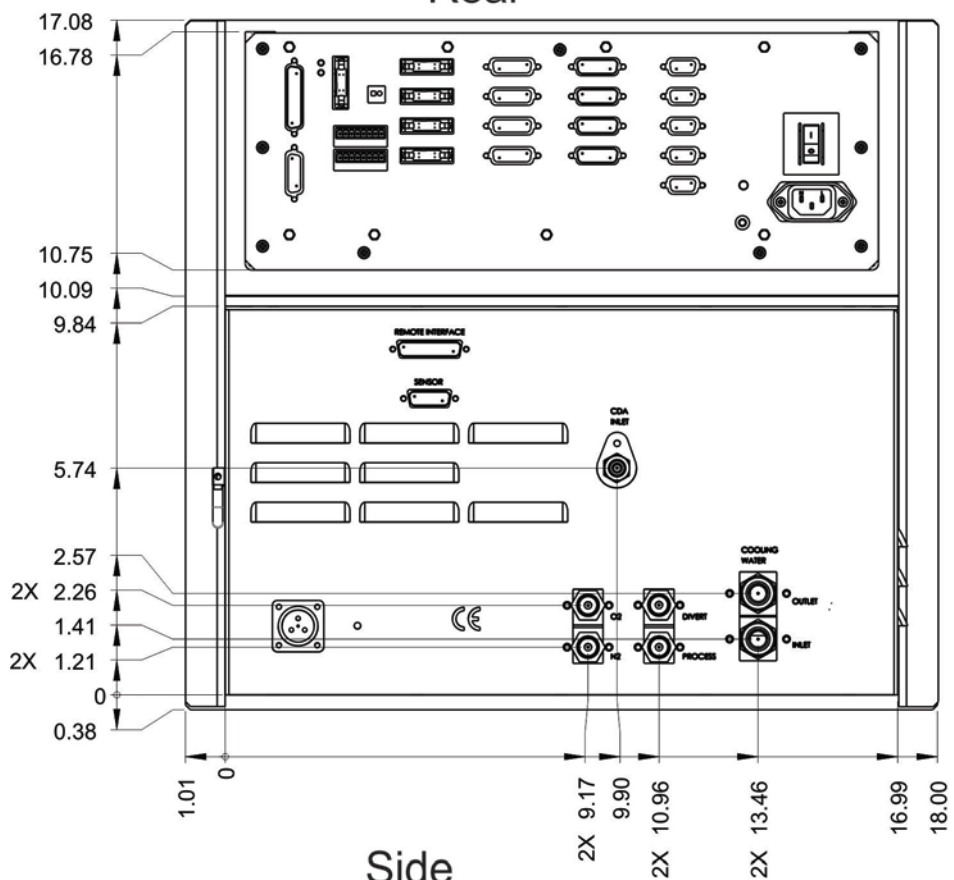

### Side

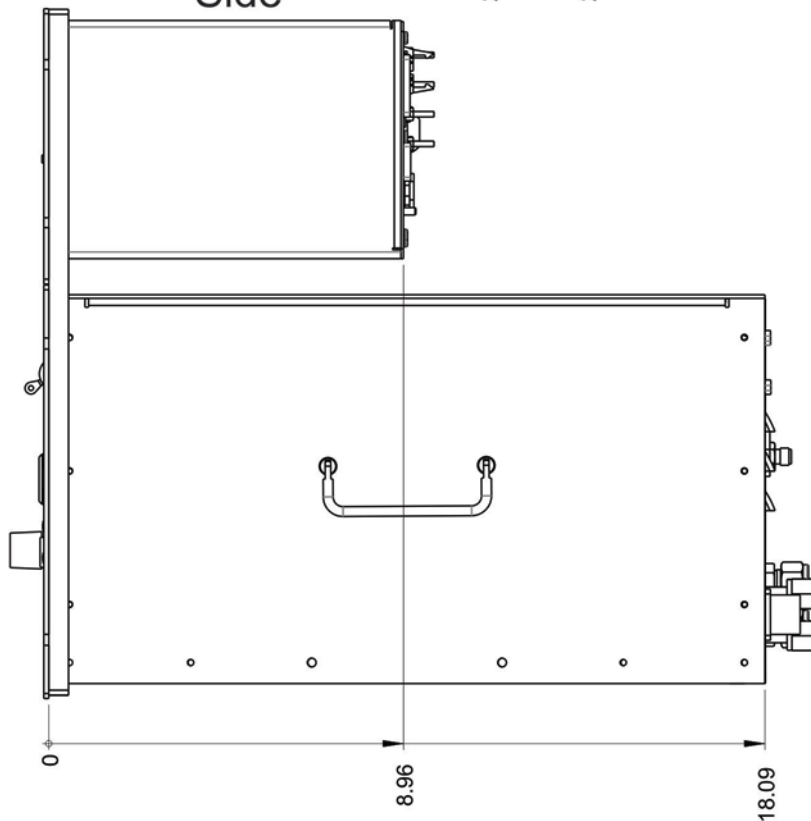



### 4.2.1 MOUNTING

The Mini ODS ozone generator system is shipped from the factory with adjoining rails connecting the generator and the controller. However, it can be mounted in a standard 19" rack. Due to its weight (70 lbs, 32 kg.), support brackets are required. The hole pattern on the front panel accepts ¼" or M6 hardware.

### 4.2.2 SERVICE SPACE REQUIREMENTS

Minimum clearances should be allowed for maintenance/service:

- Front clearance: minimum of 24" (60 cm)
- Rear clearance: minimum of 24" (60 cm)
- Side clearance: minimum of 24" (60 cm)

Clearance space can be shared space with other equipment. Refer to the component drawings for dimensions.

### 4.2.3 ENVIRONMENTAL CONSIDERATIONS

Refer to the Specifications table in Section 3.1 for ambient temperature.



#### CAUTION - TEMPERATURE SENSITIVE

Do not install within a meter of equipment which generates excessive heat, such as power supplies, transformers, blowers, exhaust ducts, heat ducts and other such equipment.

## 4.3 RECEIVING THE SYSTEM

### 4.3.1 REPORT ANY SHIPMENT DAMAGE

1. Make note of any shipment damage. Notify and then file a damage claim with the transportation carrier immediately.
2. Contact TAPI immediately.

### 4.3.2 STORING THE SYSTEM

If the system must be stored be sure to store it as follows:

- in the original shipping containers
- in an area with a nominal ambient temperature of approximately 21°C (70°F)
- in an area with less than 50% non-condensing relative humidity

## 4.7 INSTALLING THE SYSTEM

### 4.7.1 MAKING WATER AND GAS CONNECTIONS

1. Connect the cooling water inlet and outlet.
2. Connect the gas inlet and outlet lines:

Use standard gas connection techniques for the VCR fittings. Perform appropriate leak checking on each line prior to flowing gas.

- Connect the oxygen supply gas to the appropriate input fittings.
- Connect the nitrogen supply gas to the appropriate input fittings.

#### **CAUTION – SERIOUS SAFETY HAZARD**



Ozone Output ports are 1/4" male VCR. Use only Stainless Steel Gasket, Cajon Part Number SS-4-VCR- 2-GR-VS. NEVER USE NICKEL PLATED gaskets as they will interact with the ozone and cause corrosion and leakage.

The Mini ODS produces ozone gas that is available at the OZONE OUTLET ports. These are 1/4" female VCR pneumatic connectors, labeled "DIVERT" and "PROCESS". Depending on the status of the internally mounted valve, the ozone will be directed to either the "DIVERT" or the "PROCESS" port.

- Flow is directed to the "DIVERT" port when there is no pneumatic control signal applied (via the CDA inlet port).
- Flow is directed to the "PROCESS" port when there is a pneumatic control signal (60 PSI typically) at the CDA port.

#### **HAZARD – STRONG OXIDIZER**



Ozone gas is toxic. Make sure that appropriate abatement equipment is connected to the DIVERT port, located in the rear panel of the generator.

Gas flow should be piped as indicated by the labels associated to the Ozone Outlet port, located in the rear panel of the generator.

## 4.7.2 MAKING ELECTRICAL CONNECTIONS

(Refer to the SCI-552 manual for electrical connections instructions to/from the controller).



**CAUTION - QUALIFIED TECHNICIAN REQUIRED**  
Only a qualified electrician should complete these steps.



**WARNING – ELECTRICAL SHOCK HAZARD**  
High voltages that can cause injury or death to operators are present in the ODS.

1. Connect the supplied DB-25 cable from the controller to the generator:
2. Connect the supplied DB-15 cable from the controller to the generator:  
The DB-15 connects from the ozone sensor connectors on the SCI-552 to the sensor connector on the generator.

3. Connect both the controller and the generator to appropriate input power.

The system operates from 200-240 VAC, 1  $\phi$ , 50/ 60 Hz, at 10 Amp, RMS. Use appropriate wire gauge three-conductor cable terminated in a 3-pin circular style jack connector to bring the main VAC in to the unit. The following table illustrates the pin-out of the circular jack connector.

200-240 VAC, 1  $\phi$ , 50/ 60 Hz Operation, VAC Supply Connector Pin-out

Pin #	Description
A	HOT
B	NEUTRAL
C	GROUND

Make sure that pin C is connected to Ground. Use P/N 245-0204-01 (Amphenol p/n 97-3106A-16-10S) More information can be found at:

[http://www.ittcannon.com/media/pdf/catalogs/ms\\_e.pdf](http://www.ittcannon.com/media/pdf/catalogs/ms_e.pdf)

4. Ground Connection:



**WARNING – ELECTRICAL SHOCK HAZARD**  
The Mini ODS must be grounded before operation.

The Mini ODS features a threaded stud, labeled “GROUND” located in the rear panel, intended to allow for the connection, via a cable, between earth ground and the chassis. Use 12 AWG or heavier wire (green and yellow) to connect to earth ground to chassis.

### 4.7.3 INSTALL/VERIFY OPERATION OF LEAK DETECTION EQUIPMENT



#### CAUTION

Prior to operating the generator, ensure that ozone detection equipment is properly located to detect any leaks. Ensure that all other safety-monitoring features are functional.

TAPI highly recommends the use of one of our ozone monitors for ozone leak detection, as well as our Model CAT-03 Ozone Destruct Unit.

Install/Verify the operation of all leak detection equipment per the manufacturer's instructions.

### 4.8 SYSTEM INTERLOCK TESTING

Prior to normal operation, all customer-supplied system interlocks should be tested to ensure safe operation.

## 5. SYSTEM OPERATION

Ensure all precautionary messages have been followed; once started up, ensure that additional preliminary checks are completed.

### 5.1 INITIAL SYSTEM STARTUP



#### CAUTION

Prior to operating the generator, ensure that ozone detection equipment is properly located to detect any leaks. Ensure that all other safety-monitoring features are functional.



#### CAUTION

During this procedure, never over-extend your reach. If necessary, use a sturdy step stool to reach any controls or devices that you cannot easily reach.



#### CAUTION

Any interlocks must be verified prior to starting the system. All personnel must be properly trained on the function of all system components, system settings, operation, and emergency response procedures.

1. Verify that the system has been properly installed and signed off by your facility safety team.
2. Confirm the following:
  - Power switches for SCI-552 and Generator are in the OFF position.
  - Cooling water is connected to the system.
  - Oxygen supply gas is connected and pressure set to 50 PSIG.
  - Nitrogen supply gas is connected and pressure set to 55 PSIG.
  - Process exhaust port is connected to the process input.
  - Diverter exhaust port is connected to a suitable ozone catalyst.
  - Pneumatic control signal connected to the CDS inlet port.
  - SCI-552 connected to the Generator.(For details on SCI-552 connections and setup, refer to the SCI-552 manual).
3. Turn ON the SCI-552 power switch.

4. In the SCI-552 main menu display, scroll through the <TST TST> parameters and verify that the O2MFC A and B and the N2MFC A and B flow values are set to zero (0.00 V). If not, set the oxygen (O2) MFC to zero volts through the SETUP>FLOW menu (SETUP>FLOW>CH[A/B]>O2).

The nitrogen (N2) MFC does not appear in the Setup>Flow>CH[A/B] screen as it is slaved to its respective oxygen MFC so that the N2 Flow setpoint automatically recalculates to mirror any changes to the O2 Flow setpoint.

5. Once it is verified in the <TST TST> menu that the O2 MFCs are set to zero, turn ON the oxygen supply (open the oxygen supply valve).
6. Once it is verified in the <TST TST> menu that the N2 MFCs are set to zero, turn ON the nitrogen supply (open the nitrogen supply valve).
7. Set the O2 and N2 MFCs to the desired flow rate (SETUP>FLOW>CH[A/B]>O2). As stated previously, the N2 flow rate will automatically recalculate. Default N2 flow rate is 0.5% of O2 flow rate.

*MFC Setpoint* is a numerical variable. Note that the values of *MFC Setpoint* are in the range of 0 to 5 VDC. 0 VDC maps to no flow and 5 VDC maps to the maximum flow associated to the MFC. Please refer to the specifications table, Section 0. for flow rates for each system.

8. Turn ON the cooling water supply.
9. Make sure the Local/Remote switch on the ozone generator front panel is set to Local, the ON/OFF-RST to the OFF-RST position, and the potentiometer is turned all the way counter-clockwise. Power on the Generator circuit breaker.
10. Let the units purge with the gas and warm up for a few hours.

In order to achieve maximum performance and stability, it is **strongly recommended to allow an overnight warm up period on initial startup or on a "cold" start**. This warm up period should preferably be done while the unit is purging with ozone-free gas (typically oxygen). After this warm up period, the unit can be zeroed as explained below.

**NOTE:** It is recommended that the sensor be powered on at all times (24 hours/day, 7 days/week). This will ensure peak performance, minimal zero drift, and maximum system life.

11. Zero the ozone sensor (main menu display, ZERO>CH[A/B]).

### 5.1.1 LEAK TEST THE SYSTEM

To leak test the system, all gas connections must be made. For gas to fully access all regions of the system, the system must be powered up and all interlocks must be satisfied so internal isolation valves are opened.

Use standard leak testing procedures, first checking for gross leaks, then finding the source of any leak using Helium leak test techniques.

### 5.1.2 NORMAL OPERATION (LOCAL MODE)

After initial startup steps (Section 5.1):

1. Verify that water is flowing through the generator.
2. Verify that output gas can flow through to the process port.
3. Turn ON the gas feeds for Nitrogen and Oxygen and adjust flow using the SCI-552 controller (SETUP>FLOW).
4. With the generator **LOCAL/REMOTE** switch to the **LOCAL** position set the **ON/RESET** switch to **ON** and adjust the % **POWER** knob to the desired power level (turn clockwise (CW)). The SCI-552 will display the ozone gas concentration flowing into the process.

### 5.1.3 NORMAL OPERATION (REMOTE MODE CONSTANT)

After initial startup steps (Section 5.1):

1. Make sure water is flowing through the generator.
2. Make sure output gas can flow through to the process port.
3. Turn ON the gas feeds for Nitrogen and Oxygen and adjust flow using the SCI-552 controller (SETUP>FLOW).
4. With the generator **LOCAL/REMOTE** switch to the **REMOTE** position, enable the generator and adjust power level via SCI-552 controller (SETUP>O3>[CH A/CH B]>PWR). The SCI-552 will display the ozone gas concentration flowing into the process.

### 5.1.4 NORMAL OPERATION (REMOTE MODE SERVO)

After initial startup steps (Section 5.1):

1. Make sure water is flowing through the generator.
2. Make sure output gas can flow through to the process port.
3. Turn ON the gas feeds for Nitrogen and Oxygen and adjust flow using the SCI-552 controller (SETUP>FLOW).
4. With the generator **LOCAL/REMOTE** switch to the **REMOTE** position, verify that the SCI-552 has Servo enabled.
5. Adjust concentration level via SCI-552 controller (SETUP>O3>[CH A/CH B]>SERVO CONC).
6. Enable the Generator (GEN>[CHA/CHB]).

The SCI-552 will display the ozone gas concentration flowing into the process.

## 5.2 EMERGENCY SYSTEM SHUTDOWN

1. The ozone generator should be installed in a system with an Emergency Machine Off (EMO) button. Press the EMO button to immediately de-energize the system and to stop producing ozone.
2. Follow your facility's procedures for emergency shutdown notification.

### 5.3 NORMAL SYSTEM SHUTDOWN AND PURGE

This procedure should be followed to perform a normal system shutdown, for either extended idle periods or to perform system maintenance.

1. Follow your facility's procedures to notify appropriate personnel that you will perform a system shutdown, and to ensure that you are authorized to re-start the system at this time.
2. Turn the LOCAL/REMOTE switch on the ozone generator to LOCAL.
3. Turn the power level to Zero on the ozone generator (turn the % POWER knob counterclockwise (CCW) until it stops and the readout is zero). Power of the Generator with the OZONE ON OFF/RESET switch. After a few moments, the SCI-552 Controller show a decrease in the Ozone concentration.
4. Allow gas to continue to flow through the generator for 1 hour to purge/flush any residual ozone from the system. This eliminates ozone from the system. No further decontamination is required.
5. Set the MFCs to zero.
6. Turn off and lockout/tagout the feed gas supply.
7. Power off the Ozone Generator using the front panel circuit breaker.
8. Turn off and lockout/tagout the cooling water supply.



## 6. PREVENTATIVE MAINTENANCE SCHEDULES

Performance of periodic maintenance requires advanced knowledge, understanding, and training with the Ozone Generator System. NEVER perform a maintenance task unless you are trained and certified to perform the task.

### 6.1 SOLID WASTE DISPOSAL

The system requires very little maintenance and produces little waste. In addition to cleanroom wipes, which can be used to clean the external surfaces of the control cabinet, you will need to properly dispose of the system's UV lamps. See "Yearly Preventative Maintenance" on page 39.

No other system components need to be discarded at any time unless they fail. Failure of an Ozone Generator would require repair or replacement. If a destruct unit is provided with the system, disposal should be done according to local laws and regulations, or returned to the factory for proper disposal.

### 6.2 MONTHLY PREVENTATIVE MAINTENANCE

Replacement parts: None.

1. Verify the proper operation of all system interlocks. Refer to the supplied interlock testing procedure.
2. The sensor on each ozone sensor should be checked according to the provided instructions.

### 6.3 YEARLY PREVENTATIVE MAINTENANCE

Refer to parts list and replacement instructions in each device's manual.

#### 6.3.1 MFCs

Verify the calibration of the installed Mass Flow Controllers, according to their manufacturer's recommendations.

#### 6.3.2 OZONE SENSOR MAINTENANCE

The ozone sensor is designed to operate continuously with minimal maintenance requirements.

Only the UV lamp will need to be replaced on a periodic basis (every 24-36 months). (Refer to the ozone sensor manual provided with the documentation for this system). Lamp replacement does not change calibration and can be done while the sensor is on line and while gas is flowing through it.

After lamp replacement, re-zero unit following the after start-up zeroing procedure.

The use of particulate filters on the gas inlet of the monitor is recommended in order to minimize the risk of optical component soiling.

**CAUTION - UV RADIATION HAZARD**



DO NOT look directly at a UV lamp as irreversible, disabling eye damage can occur. Always wear proper eye protection equipment when calibrating UV lamps to prevent accidental exposure. Carefully follow bulb replacement and adjustment procedures, as directed by the bulb maintenance instructions.

**CAUTION - TOXIC HAZARD**



UV lamps contain trace amounts of Mercury. Handle bulbs with extreme care to prevent shattering. Wear appropriate gloves, glasses, and any required safety equipment to prevent exposure to this dangerous element.

Refer to the Ozone Sensor manual for UV lamp adjustment and replacement procedures

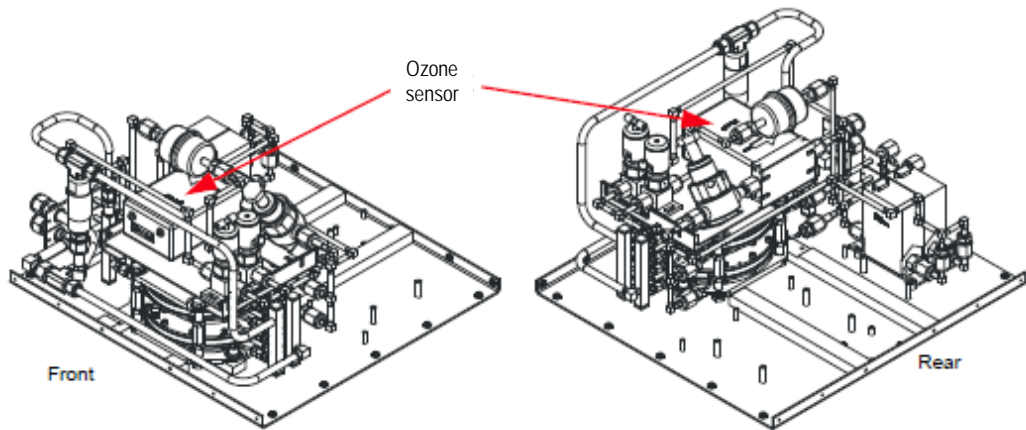

## 7. TROUBLESHOOTING

This section presents troubleshooting for the generator and for the controller.

### 7.1 OZONE GENERATOR

This section provides corrective action instructions for troubleshooting causes of faults indicated by the respective LED, and as well as those for possible performance faults.

#### 7.1.1 STATUS FAULT TROUBLESHOOTING

LED State	Possible Causes	Corrective Action
READY not lit	Overvoltage LED lit Internal interlock LED lit System fault LED lit	Confirm outlet pressure within specifications Check cooling water flow Check remote interface connection
OVERVOLTAGE Lit	Cell pressure too low Line voltage high	Confirm outlet pressure within specifications Confirm input line voltage
INTERNAL INTERLOCK Lit	Low cooling water flow No cooling water flow Interlock switch failure	Check cooling water flow Call Technical Support
SYSTEM FAULT Lit	Inlet water >>20°C Low water flow No water flow Cooling fan failure	Decrease temperature of water to ≤ 20°C Increase water flow Verify water flow input and output Call customer service
EXTERNAL INTERLOCK Lit	Interface cable disconnected SCI-552 is powered off Error messages on SCI-552 screen SCI-552 failure	Reconnect interface cable to SCI-552 Check power connections, power on SCI-552 Refer to the SCI-552 troubleshooting guide Call Technical Support

## 7.1.2 PERFORMANCE FAULT TROUBLESHOOTING

Symptom	Possible Causes	Corrective Action
Low ozone concentration relative to operating specifications	Low Nitrogen flow Gas flow too high	Confirm Nitrogen flow rate conforms to specifications. Verify flow-metering device setpoint and calibration
	Cell pressure too high or too low	Confirm outlet pressure conforms to specifications
	Cooling Water Temperature too high	Decrease temperature of water
	Gas feed purity problem	Purge for several hours with grade 6 O <sub>2</sub>
	Ozone analyzer error	Refer to ozone analyzer manual
	Low cooling water flow	Increase flow of water
	Ozone generator open to air	Check integrity of seals, fittings, lines, and cabinet. Generate ozone for seven hours
Unstable Concentration	Unstable gas flow	Verify flow-metering setpoint and calibration
	Unstable pressure	Confirm outlet pressure conforms to specifications
	Ozone analyzer error	Refer to ozone analyzer manual
	Unstable temperature of cooling water	Verify water temperature
	Unstable cooling water flow	Verify integrity of water system and water flow
	Unstable power	Verify line voltage within specifications
High Concentration	Gas flow too low	Verify flow-metering device calibration.
	Cell pressure problem	Confirm outlet pressure conforms to specifications
	Water temperature too low	Increase temperature of water
	Ozone analyzer error	Refer to ozone analyzer manual
	Power control is not operational	Reduce power level and verify reduction of ozone concentration

If still unable to resolve after implementing the corrective actions, contact Technical Support.

## 7.2 SCI-552 CONTROLLER

The SCI-552 manual contains setup and operation instructions, including the following information related to front panel display messages, which are included here for the user's convenience.

-

Warning Messages	Cause	Remarks/Possible Solutions
SYSTEM STARTUP	System restart due to power cycle or power failure	Press CLR
CABINET INTERLOCK	Hardware INTERLOCK connector on rear panel is electrically open.	Troubleshoot the external, facility interlock system
CHILLER INTERLOCK		Contact Technical Support
PRESSURE INTERLOCK		Contact Technical Support
COMM INTERLOCK		Contact Technical Support
EXTERNAL INTERLOCK		Contact Technical Support

## 7.3 TECHNICAL ASSISTANCE

If you encounter a problem that you can't seem to solve, follow the basic steps outlined below.

1. Review all of the information contained in this manual.
2. Consult the appropriate guides listed in *Related Documents* found earlier in this chapter of the guide.
3. Consult your own internal people about the issue.
4. Contact your local field service office about the issue.
5. Contact TAPI Technical Support about the issue:

Teledyne API  
 ATTN Technical Support  
 9970 Carroll Canyon Road  
 San Diego, CA 92131-1106  
 U.S.A.  
 Telephone: (toll free) 800-324-5190  
                   +1 858-657-9800  
 Fax:                  +1 858-657-9816

TAPI Technical Support can also be contacted for parts, technical publications, and training.